

# TECHNICAL DATA

SINGLE DRUM ROLLERS

BW 219 DH-5, BW 219 PDH-5

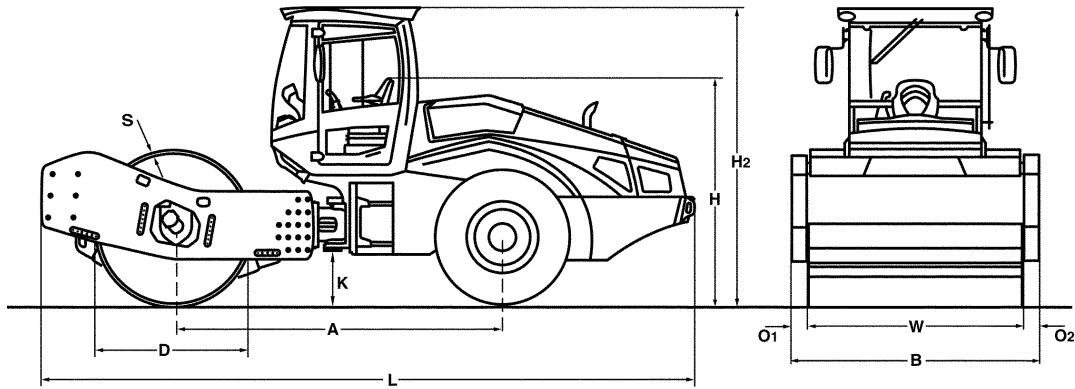



**Dimensions in mm**

	A	B	D	H	H2	K	L	O1	O2	S	W
BW 219 DH-5	3255	2300	1600	2300	3040	495	6500	85	85	40	2130
BW 219 PDH-5	3255	2300	1500	2300	3060	495	6500	85	85	35	2130

**Shipping dimensions in m3**

BW 219 DH-5  
 BW 219 PDH-5

**without ROPS**

34,385  
 34,385

**with ROPS**

45,448  
 45,747

Machine type	Compaction output (m3/h)			
	Rock fill	Gravel, sand	Mixed soil	Silt, clay
BW 219 DH-5	940-1880	700-1400	560-960	250-500
BW 219 PDH-5	940-1880	700-1400	560-960	280-560

Machine type	Compacted layer thickness (m)			
	Rock fill	Gravel, sand	Mixed soil	Silt, clay
BW 219 DH-5	1,40	1,00	0,70	0,35
BW 219 PDH-5	1,60	1,20	0,80	0,40

**Technical Data****BOMAG  
BW 219 DH-5****BOMAG  
BW 219 PDH-5****Weights**

Grossweight .....	kg	22.000	21.000
Operating weight CECE w. ROPS-cabin .....	kg	19.400	20.000
Axle load, drum CECE .....	kg	12.800	13.200
Axle load, wheels CECE .....	kg	6.600	6.800
Static linear load CECE .....	kg/cm	60,1	

**Dimensions**

Working width .....	mm	2.130	2.130
Track radius, inner .....	mm	4.120	4.120

**Driving Characteristics**

Speed .....	km/h	0- 10,0	0- 10,0
Max. gradeability without/with vibr. ....	%	60/57	62/60

**Drive**

Engine manufacturer .....		Deutz	Deutz
Type .....		TCD 6.1 L6	TCD 6.1 L6
Emission stage .....		Stage V / TIER4f	Stage V / TIER4f
Exhaust gas aftertreatment .....		DOC+DPF+SCR	DOC+DPF+SCR
Cooling .....		Liquid	Liquid
Number of cylinders .....		6	6
Performance ISO 3046 .....	kW	150,0	150,0
Performance SAE J 1995 .....	hp	202,0	202,0
Speed .....	min-1	2.300	2.300
Fuel .....		Diesel	Diesel
Electric equipment .....	V	12	12
Drive system .....		hydrost.	hydrost.
Drum driven .....		standard	standard

**Drums and Tyres**

Number of pad feet .....			150
Area of one pad foot .....	cm2		137
Height of pad feet .....	mm		100
Tyre size .....		23.1-26 12PR	23.1-26 12PR

**Brakes**

Service brake .....		hydrost.	hydrost.
Parking brake .....		hydromec.	hydromec.

**Steering**

Steering system .....		oscil.artic.	oscil.artic.
Steering method .....		hydrost.	hydrost.
Steering / oscillating angle +/- .....	grad	35/12	35/12

**Exciter system**

Drive system .....		hydrost.	hydrost.
Frequency .....	Hz	26/31	26/31
Amplitude .....	mm	2,10/1,20	1,90/1,00
Centrifugal force .....	kN	328/266	328/245
Centrifugal force .....	t	33,5/27,1	33,5/25,0

**Capacities**

Fuel .....	l	280,0	280,0
------------	---	-------	-------

Technical modifications reserved. Machines may be shown with options.

### Standard Equipment

- BOMAG ECOMODE
- Double pump system for travel drive
- Self locking differential
- Rear axle with twin spring accumulator brakes
- Hydrostatic travel and vibration drive
- Hydrostatic articulated steering
- Articulated joint lock
- Seat with arm rest and adj. for position and height
- Battery disconnect switch
- Single lever control for travel and vibration
- Warning, information and operation displays with LCD
- Loading mode
- Emergency STOP
- Working lights front / rear
- Back-up alarm
- 2 Scrapers
- Warning horn
- Tractor tires (PDH)

### Optional Equipment

- \* ROPS/FOPS cabin with seat belts
  - Sliding window
- Rearview camera
- Air condition
- Radio (Bluetooth)
- Pre start cabin heating
- Comfort package: Adjustable seat and adjustable steering column
- Rotary beacon
- Indicator and hazard lights
- BOMAG ECOSTOP
- ECONOMIZER
- TERRAMETER
- BOMAG TELEMATIC POWER
- Special painting
- Padfoot segment kit (DH)
- Environmentally compliant hydraulic oil
- Measuring- and machine data interface for third-party suppliers
- Reversing alarm buzzer with broad band audio
- LED Working lights (Cabin)
- Highly wear resistant drum (DH)
- Rock tyre

\* Standard delivery with CE conformity  
(valid within European Union)

