

Technical Data - B40E

ENGINE

Manufacturer
Mercedes Benz (MTU)

Model
OM471LA (MTU 6R 1300)

Configuration
Inline 6, turbocharged and intercooled.

Gross Power
380 kW (510 hp) @ 1 700 rpm

Net Power
359 kW (481 hp) @ 1 700 rpm

Gross Torque
2 380 Nm (1 755 lbf) @ 1 300 rpm

Displacement
12,8 litres (781 cu.in)

Auxiliary Brake
Exhaust Valve Brake

Fuel Tank Capacity
352 litres (93 US gal)

Certification
OM471LA (MTU 6R 1300) is EU Stage IIIA / EPA Tier 3 emission level equivalent.

TRANSMISSION

Manufacturer
Allison

Model
4700 ORS

Configuration
Fully automatic planetary transmission.

Layout
Engine mounted

Gear Layout
Constant meshing planetary gears, clutch operated

Gears
7 Forward, 1 Reverse

Clutch Type
Hydraulically operated multi-disc

Control Type
Electronic

Torque Control
Hydrodynamic with lock-up in all gears.

TRANSFER CASE

Manufacturer
Bell VGR

Model
18050

Layout
Remote mounted

Gear Layout
Three in-line helical gears

Output Differential
Interaxle 33/67 proportional differential. Automatic inter-axle differential lock.

AXLES

Manufacturer
Bell

Model
30T

Differential
High input controlled traction differential with spiral bevel gears

Final Drive

Outboard heavy duty planetary on all axles.

BRAKING SYSTEM

Service Brake
Dual circuit, full hydraulic actuation wet disc brakes on front and middle axles. Wet brake oil is circulated through a filtration and cooling system.

Maximum brake force:
305 kN (68 567 lbf)

Park & Emergency
Spring applied, air released driveline mounted disc.

Maximum brake force:
218 kN (49 008 lbf)

Auxiliary Brake
Automatic engine valve brake. Automatic retardation through electronic activation of wet brake system.

Total Retardation Power
Continuous: 442 kW (593 hp)
Maximum: 854 kW (1 145 hp)

WHEELS

Type
Radial Earthmover

Tyre
29.5 R 25 (875/65 R 29 optional)

FRONT SUSPENSION

Semi-independent, leading A-frame supported by hydro-pneumatic suspension struts.

Option: Electronically controlled adaptive suspension with ride height adjustment.

REAR SUSPENSION

Pivoting walking beams with laminated rubber suspension blocks.

Option: Comfort Ride suspension walking beams, with two-stage sandwich block.

HYDRAULIC SYSTEM

Full load sensing system serving the prioritized steering, body tipping and brake functions. A ground-driven, load sensing emergency steering pump is integrated into the main system.

Pump Type

Variable displacement load sensing piston

Flow

330 L/min (87 gal/min)

Pressure

315 bar (4 569 psi)

Filter

5 microns

STEERING SYSTEM

Double acting cylinders, with ground-driven emergency steering pump.

Lock to lock turns

5

Steering Angle

42°

DUMPING SYSTEM

Two double-acting, single stage, dump cylinders.

Raise Time

11 seconds

Lowering Time

6 seconds

Tipping Angle

70 deg standard, or any lower angle programmable

PNEUMATIC SYSTEM

Air drier with heater and integral unloader valve, serving park brake and auxiliary functions.

System Pressure

810 kPa (117 psi)

ELECTRICAL SYSTEM

Voltage

24 V

Battery Type

Two AGM (Absorption Glass Mat) type.

Battery Capacity

2 X 75 Ah

Alternator Rating

28V 80A

MAX. VEHICLE SPEED

1st	4 km/h	2,5 mph
2nd	9 km/h	6 mph
3rd	17 km/h	11 mph
4th	23 km/h	14 mph
5th	33 km/h	21 mph
6th	44 km/h	27,3 mph
7th	51 km/h	32 mph
R	7 km/h	4 mph

CAB

ROPS/FOPS certified 74 dBA internal sound level measured according to ISO 6396.

Load Capacity & Ground Pressure

OPERATING WEIGHTS		GROUND PRESSURE*		LOAD CAPACITY		OPTION WEIGHTS	
UNLADEN	kg (lb)	LADEN		BODY	m ³ (yd ³)		
Front	17 012 (37 505)	(No sinkage/Total Contact Area Method)		Struck Capacity	19 (25)	Bin liner	1 369 (3 018)
Middle	7 695 (17 965)	29.5 R 25	kPa (Psi)	SAE 2:1 Capacity	24 (31)	Tailgate	984 (2 169)
Rear	7 080 (15 609)	Front	310 (45)	SAE 1:1 Capacity	28,5 (37)	875/65 R29	
Total	31 787 (70 078)	Mid & Rear	341 (50)	SAE 2:1 Capacity with Tailgate	24,5 (32)	(per vehicle) Add	1 182 (2 606)
LADEN						EXTRA WHEELSET	
Front	21 887 (48 253)	875/65 R29	kPa (Psi)			29.5 R 25	800 (1 764)
Middle	24 757 (54 580)	Front	293 (43)	Rated Payload	39 000 kg	875/65 R29	1 024 (2 258)
Rear	24 143 (53 226)	Mid & Rear	329 (48)		(85 980 lb)		
Total	70 787 (156 059)						

* 29.5R25 Groundpressures calculated with Michelin XADN+ Tyre. 875/65R29 Groundpressures calculated with Michelin XAD65-1 Tyre.

Dimensions

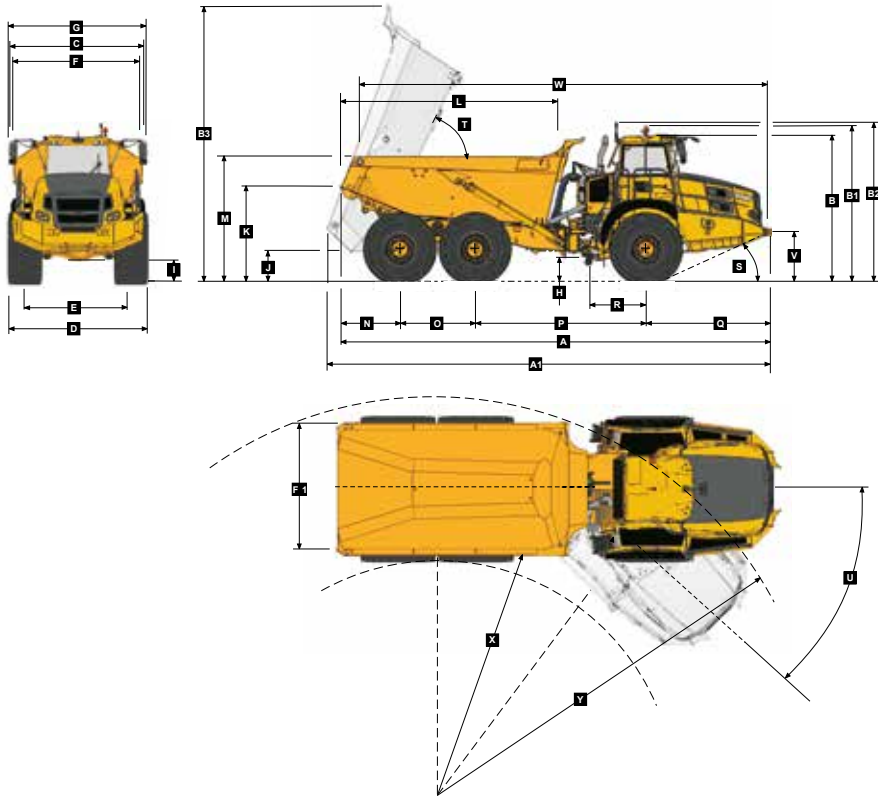

Machine Dimensions

A	Length - Transport Position with Tailgate	11197 mm (36 ft. 9 in.)
A	Length - Transport position w/o Tailgate	11186 mm (36 ft. 8 in.)
A1	Length - Bin Fully Tipped	11742 mm (38 ft. 6 in.)
B	Height - Transport Position	3804 mm (12 ft. 6 in.)
B1	Height - Rotating Beacon	4040 mm (13 ft. 3 in.)
B2	Height - Load Light	4129 mm (13 ft. 7 in.)
B3	Bin Height - Fully Tipped	7316 mm (24 ft.)
C	Width over Mudguards	3495 mm (11 ft. 6 in.)
D	Width over Tyres - 875/65 R29	3656 mm (11 ft. 12 in.)
D	Width over Tyres - 29.5R25	3487 mm (11 ft. 5 in.)
E	Tyre Track Width - 875/65 R29	2773 mm (9 ft. 1 in.)
E	Tyre Track Width - 29.5R25	2725 mm (8 ft. 11 in.)
F	Width over Bin	3372 mm (11 ft.)
F1	Width over Tailgate	3662 mm (12 ft.)
G	Width over Mirrors - Operating Position	3614 mm (11 ft. 10 in.)
H	Ground Clearance - Artic	545 mm (21.46 in.)
I	Ground Clearance - Front Axle	545 mm (21.46 in.)
J	Ground Clearance - Bin Fully Tipped	876 mm (34.5 in.)
K	Bin Lip Height - Transport Position	2519 mm (8 ft. 3 in.)
L	Bin Length	5742 mm (18 ft. 10 in.)
M	Load over Height	3271 mm (10 ft. 9 in.)
N	Rear Axle Centre to Bin Rear	1543 mm (5 ft.)
O	Mid Axle Centre to Rear Axle Centre	1950 mm (6 ft. 5 in.)
P	Mid Axle Centre to Front Axle Centre	4438 mm (14 ft. 7 in.)
Q	Front Axle Centre to Machine Front	3255 mm (10 ft. 8 in.)
R	Front Axle Centre to Artic Centre	1558 mm (5 ft. 1 in.)
S	Approach Angle	24°
T	Maximum Bin Tip Angle	70°
U	Maximum Articulation Angle	42°
V	Front Tie Down Height	1265 mm (4 ft. 2 in.)
W	Machine Lifting Centres	10594 mm (34 ft. 9 in.)
X	Inner Turning Circle Radius - 875/65R29	4782 mm (15 ft. 8 in.)
X	Inner Turning Circle Radius - 29.5R25	4866 mm (15 ft. 12 in.)
Y	Outer Turning Circle Radius - 875/65R29	9320 mm (30 ft. 7 in.)
Y	Outer Turning Circle Radius - 29.5R25	9235 mm (30 ft. 4 in.)

Grade Ability/Rimpull

- Determine tractive resistance by finding intersection of vehicle mass line and grade line. NOTE: 2% typical rolling resistance is already assumed in chart and grade line.
- From this intersection, move straight right across charts until line intersects rimpull curve.
- Read down from this point to determine maximum speed attained at that tractive resistance.

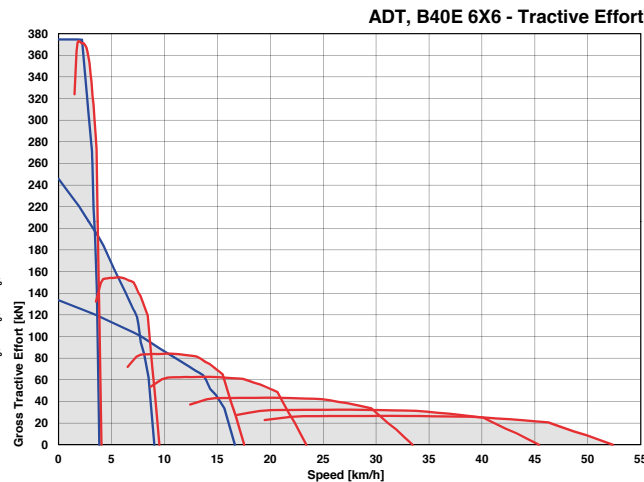
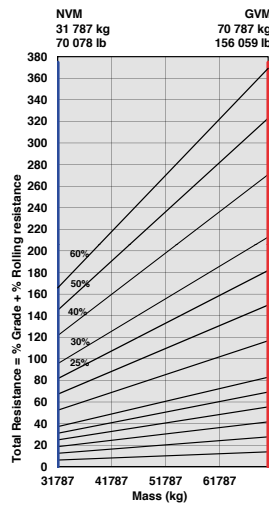

Retardation

- Determine tractive resistance by finding intersection of vehicle mass line and grade line. NOTE: 2% typical rolling resistance is already assumed in chart and grade line.
- From this intersection, move straight right across charts until line intersects the curve.
- Read down from this point to determine maximum speed.

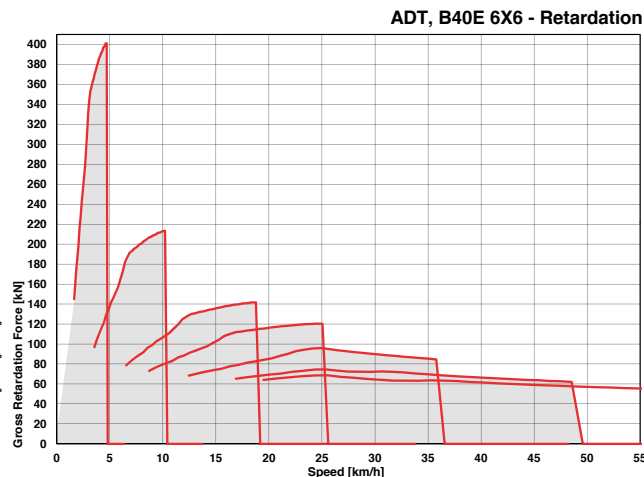
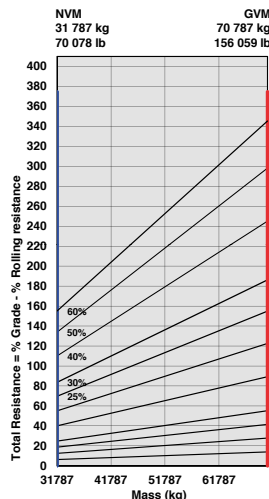

Features and Options

B35E	B40E	B45E	B50E	● STANDARD	▲ OPTION
ENGINE					
●	●	●	●	●	Engine valve brake
●	●	●	●	●	Dual element air cleaner with dust ejector valve
●	●	●	●	●	Precleaner with automatic dust scavenging
●	●	●	●	●	Water separator
●	●	●	●	●	Serpentine drive belt with automatic tensioner
●	●	●	●	●	Provision for fast fill
●	●	●	●	●	Wet-sleeve cylinder liners
COOLING					
●	●	●	●	●	Crankshaft mounted electronically controlled viscous fan drive
●	●	●	●	●	Fan guard
PNEUMATIC SYSTEM					
●	●	●	●	●	Engine-mounted compressor
●	●	●	●	●	Air drier with heater
●	●	●	●	●	Integral unloader valve
ELECTRICAL SYSTEM					
●	●	●	●	●	Battery disconnect
●	●	●	●	●	Drive lights
●	●	●	●	●	Air horn
●	●	●	●	●	Reverse alarm
▲	▲	▲	▲	▲	White noise reverse alarm
●	●	●	●	●	Rotating beacon
●	●	●	●	●	Pitch Roll Sensor
●	●	●	●	●	Artic reverse light
STEERING SYSTEM					
▲	▲	▲	▲	▲	Bi-directional ground-driven secondary steering pump
●	●	●	●	●	Ground-driven secondary steering pump
CAB					
●	●	●	●	●	ROPS/FOPS certification
●	●	●	●	●	Tilt cab
●	●	●	●	●	Gas strut-supported door
●	●	●	●	●	I-Tip programmable dump-body tip settings
●	●	●	●	●	HVAC Climate control system
▲	▲	▲	▲	▲	AM/FM radio/CD player
●	●	●	●	●	Rear window guard
●	●	●	●	●	Wiper/washer with intermittent control
●	●	●	●	●	Tilt and telescoping steering wheel
●	●	●	●	●	Centre-mount air-suspension seat
▲	▲	▲	▲	▲	Forward work lights
▲	▲	▲	▲	▲	LED work lights
▲	▲	▲	▲	▲	Rotating beacon: seat belt installation
▲	▲	▲	▲	▲	Remote engine and machine isolation
●	●	●	●	●	Remote battery jump start
●	●	●	●	●	Retractable 3 point seat belt
●	●	●	●	●	Foldaway trainer seat with retractable seat belt
●	●	●	●	●	12-volt power outlet
●	●	●	●	●	Cab utility bin (removable)
●	●	●	●	●	Cup holder

B35E	B40E	B45E	B50E	● STANDARD	▲ OPTION
CAB (continued)					
●	●	●	●	●	Cooled/heated lunch box
▲	▲	▲	▲	▲	Electric adjustable and heated mirrors
●	●	●	●	●	Deluxe 10" colour LCD:
				●	Speedometer / Fuel gauge /
				●	Transmission oil temperature gauge /
				●	Engine coolant temperature gauge /
				●	LED function/warning indicators and audible alarm / Transmission gear selection /
				●	Tachometer / Battery voltage / Hour meter /
				●	Odometer / Fuel consumption / Tip counter /
				●	Trip timer / Trip distance / Metric/English units /
				●	Service codes/diagnostics
●	●	●	●	●	Backlit sealed switch module functions with:
				●	Wiper control / Lights / Heated mirrors /
				●	Retarding aggressiveness / Transfer case differential lock / Transmission gear hold /
				●	Dump-body tip limit / Automatic dump-body tip settings / Airconditioner/ Heater controls /
				●	Preselected Speed Control
DUMP BODY					
●	●	●	●	●	Dump body mechanical locks (x2). Partially up and fully up
▲	▲	▲	▲	▲	Body liner
▲	▲	▲	▲	▲	Tailgate
▲	▲	▲	▲	▲	Body heater
▲	▲	▲	▲	▲	Less dump body and cylinders
▲	▲	▲	▲	▲	Low SG bin extensions
▲	▲	▲	▲	▲	Bin pole lockout
OTHER					
●	●	●	●	●	Automatic Traction Control (ATC)
●	●	●	●	●	Wet disc brakes
●	●	●	●	●	26.5 R 25 Radial Earthmover tyres
●	●	●	▲	▲	29.5 R 25 Radial Earthmover tyres
●	●	●	●	●	875/65 R 29 Radial Earthmover tyres
●	●	●	●	●	Remote grease banks
▲	▲	▲	●	●	Automatic greasing
●	●	●	●	●	Onboard weighing
▲	▲	▲	▲	▲	Load lights: stack
▲	▲	▲	▲	●	Comfort ride suspension (Front)
▲	▲	▲	▲	▲	Comfort ride suspension (Rear)
▲	▲	▲	▲	▲	Reverse camera
▲	▲	▲	▲	▲	Hand rails
●	●	●	●	●	Cab peak
▲	▲	▲	▲	▲	High pressure hydraulic filter
▲	▲	▲	▲	▲	Fuel heater
●	●	●	●	●	Belly cover
▲	▲	▲	▲	▲	Remote transmission filters
●	●	●	●	●	Engine and transmission remote drain-gravity
●	●	●	●	●	Engine and transmission remote drain-scavenge
▲	▲	▲	▲	▲	Window smash button
●	●	●	●	●	High visibility mirrors
●	●	●	●	●	Fleetm@tic Classic Package for 2 years

All dimensions are shown in millimetres, unless otherwise stated between brackets. Under our policy of continuous improvement, we reserve the right to change technical data and design without prior notice. Photographs featured in this brochure may include optional equipment. Blu@dvantage™ is a trademark of Bell Equipment Co. (PTY) Ltd. AdBlue® is a registered trademark of VDA.

BELL INTERNATIONAL: Tel: +27 (0)35-907 9431

E-mail: marketing@bellequipment.com

Web: www.bellequipment.com

 Tel: +61 (0)8-9356-1033

 Tel: +33 (0)5-55-89-23-56

 Tel: +49 (0)6631 / 91-13-0

 Tel: +7-495-287-80-02

 Tel: +27 (0)11-928-9700

 Tel: +1-855-494-2355

 Tel: +44 (0)1283-712862

**Strong Reliable Machines
Strong Reliable Support**

BELL